

ENGINE

Model Cummins B4.5

Type:

Water-cooled, 4-cycle diesel, 4-cylinder in line, High pressure common rail system (electric control), turbocharger with air cooled intercooler, DOC+DPF+SCR, EGR free.

Emissions Certification Tier 4 Final/Stage V

Cylinders 4

Displacement 274.6 in³ (4.5 L)

Rated flywheel horse power:

ISO 9249 at 2200 RPM 170 hp (127 kW)

ISO 14396 at 2200 RPM 173 hp (129 kW)

Maximum torque:

ISO 14396 at 1500 RPM 575 ft-lb (780 Nm)

HYDRAULIC SYSTEM

Main pump Variable displacement piston pump

Max. oil flow at 1800 RPM:

68.9 gpm (261 L/min)

Working circuit pressure:

Boom/Arm/Bucket:

4,975 psi (34.3 MPa) - 5,410 psi (37.3 MPa) with auto power boost

Swing circuit 3,844 psi (26.5 MPa)

Travel circuit 5,410 psi (37.3 MPa)

Pilot circuit 493 psi (3.4 MPa)

SWING

Swing motor:

Fixed displacement radial piston motor

Maximum swing speed 9.5 RPM

Swing torque 28,839 ft-lb (39 100 Nm)

Brake system Automatic, spring applied hydraulic released

ELECTRICAL SYSTEM

Voltage 24 V

Alternator 95 Amp

Starter 24 V - 4.8 kW

Battery 2 X 12 V 100 Ah

STEERING

Type Orbitrol steering system

Minimum turning radius 20 ft 8 in (6.3 m)

AXLES

Type:

4 wheel drive with differential, oscillating front axle with automatic or operator controlled oscillation lock, fixed rear axle.

Brake type Wet multi-disc

Parking brake type Wet multi-disc integrated in transmission

UNDERCARRIAGE

Transmission 2 speed hydrostatic powershift

Travel motor Variable displacement bent-axis axial piston motor

High travel speed (Automatic travel speed shifting): 22 mph (35 km/h)

Low travel speed 6.2 mph (10 km/h)

Creep speed 1.9 mph (3 km/h)

Drawbar pull 20,458 lbf (91 kN)

Gradeability 70% (35°)

NOISE

External sound level LwA 100 dB(A)

Operator cab sound pressure level:

LpA 71 dB(A)

CIRCUIT AND COMPONENT CAPACITIES

Fuel tank 53 gal (200 L)

Hydraulic system 49.4 gal (187 L)

Hydraulic tank 27.2 gal (103 L)

DEF tank 12.7 gal (48 L)

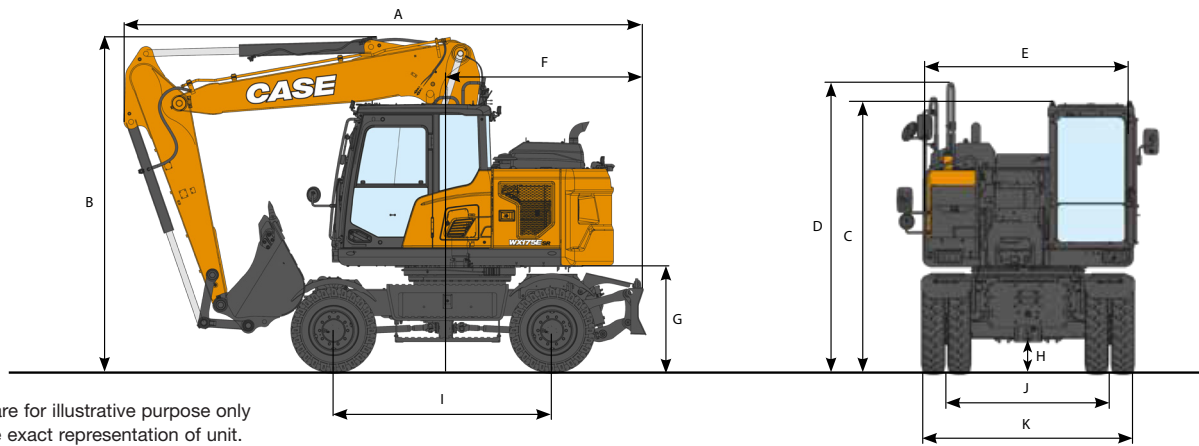

Line drawings are for illustrative purpose only and may not be exact representation of unit.

GENERAL DIMENSIONS - 2-PIECE BOOM

	8 ft (2.45 m) Arm	6 ft 7 in (2.00 m) Arm	8 ft 6 in (2.60 m) Arm
A. Overall length (with attachment):			
Traveling	20 ft 8 in (6 310 mm)	20 ft 10 in (6 340 mm)	20 ft 6 in (6 250 mm)
Transportation	25 ft 9 in (7 860 mm)	25 ft 11 in (7 900 mm)	25 ft 8 in (7 820 mm)
B. Overall height (to top of boom):			
Traveling	12 ft 11 in (3 940 mm)	12 ft 11 in (3 940 mm)	13 ft 0 in (3 960 mm)
Transportation	9 ft 6 in (2 900 mm)	9 ft 8 in (2 940 mm)	10 ft 4 in (3 150 mm)
C. Cab height	10 ft 7 in (3 220 mm)	10 ft 7 in (3 220 mm)	10 ft 7 in (3 220 mm)
D. Overall height (to top of handrail)	10 ft 9 in (3 275 mm)	10 ft 9 in (3 275 mm)	10 ft 9 in (3 275 mm)
E. Upper structure overall width	8 ft 2 in (2 500 mm)	8 ft 2 in (2 500 mm)	8 ft 2 in (2 500 mm)
F. Swing (rear end) radius	6 ft 0 in (1 830 mm)	6 ft 0 in (1 830 mm)	6 ft 0 in (1 830 mm)
G. Clearance height under upper structure	4 ft 2 in (1 265 mm)	4 ft 2 in (1 265 mm)	4 ft 2 in (1 265 mm)
H. Minimum ground clearance	1 ft 3 in (370 mm)	1 ft 3 in (370 mm)	1 ft 3 in (370 mm)
I. Wheel base (center-to-center of wheels)	8 ft 6 in (2 600 mm)	8 ft 6 in (2 600 mm)	8 ft 6 in (2 600 mm)
J. Wheel gauge	6 ft 5 in (1 944 mm)	6 ft 5 in (1 944 mm)	6 ft 5 in (1 944 mm)
	6 ft 11 in (2 114 mm)	6 ft 11 in (2 114 mm)	6 ft 11 in (2 114 mm)
K. Undercarriage overall width	8 ft 4 in (2 530 mm)	8 ft 4 in (2 530 mm)	8 ft 4 in (2 530 mm)

WEIGHT - 2-PIECE BOOM

Rear blade	41,404 lb (18 820 kg)
Front blade and rear stabilizers	44,088 lb (20 040 kg)
Standard counterweight	9,259 lb (4 200 kg)

NOTE: With 8 ft (2.45 m) arm, 24.7 ft³ (0.70 m³) bucket, 10.00x20 twin tires, standard counterweight, operator, lubricant, coolant, full fuel tank.

PERFORMANCE - 2-PIECE BOOM

	8 ft (2.45 m)	6 ft 7 in (2 m)	8 ft 6 in (2.6 m)
Boom length	16 ft 9 in (5 097 mm)	16 ft 9 in (5 097 mm)	16 ft 9 in (5 097 mm)
A. Maximum reach at groundline	28 ft 8 in (8 750 mm)	27 ft 2 in (8 280 mm)	28 ft 11 in (8 820 mm)
B. Maximum reach	29 ft 4 in (8 950 mm)	27 ft 10 in (8 490 mm)	29 ft 7 in (9 020 mm)
C. Max. digging depth	17 ft 10 in (5 440 mm)	16 ft 4 in (4 980 mm)	18 ft 3 in (5 565 mm)
D. Max. digging height	32 ft 1 in (9 785 mm)	30 ft 9 in (9 370 mm)	31 ft 9 in (9 680 mm)
E. Max. dumping height	23 ft 2 in (7 060 mm)	21 ft 10 in (6 660 mm)	22 ft 11 in (6 980 mm)
F. Min. swing radius	10 ft 0 in (3 040 mm)	11 ft 1 in (3 380 mm)	11 ft 6 in (3 500 mm)

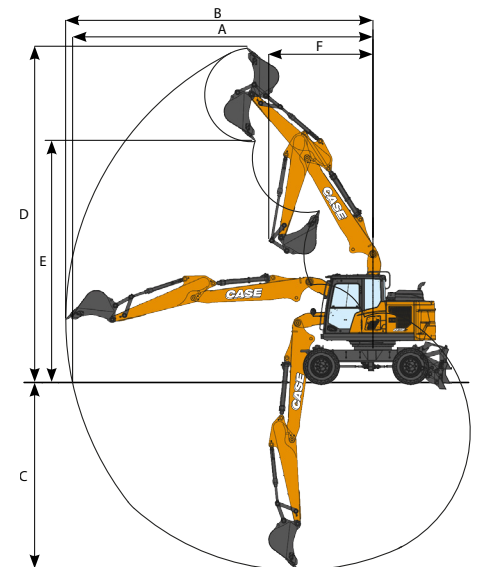

DIGGING FORCE - 2-PIECE BOOM

	8 ft (2.45 m) Arm	6 ft 7 in (2 m) Arm	8 ft 6 in (2.6 m) Arm
Arm digging force	15,736 lbf (70 kN)	20,007 lbf (89 kN)	15,736 lbf (70 kN)
with Auto power up	17,310 lbf (77 kN)	22,030 lbf (98 kN)	17,085 lbf (76 kN)
Bucket digging force	25,852 lbf (115 kN)	25,852 lbf (115 kN)	25,852 lbf (115 kN)
with Auto power up	28,100 lbf (125 kN)	28,100 lbf (125 kN)	28,325 lbf (126 kN)

LIFTING CAPACITIES - 2-PIECE BOOM

Load/Lift Point Height	LOAD RADIUS								MAXIMUM REACH			
	4 ft 11 in (1.5 m)		9 ft 10 in (3.0 m)		14 ft 9 in (4.5 m)		19 ft 8 in (6.0 m)		REACH	CAPACITY		
	END	SIDE	END	SIDE	END	SIDE	END	SIDE	@	END	SIDE	
REAR BLADE DOWN - 2-piece boom 16 ft 9 in (5.097 m), arm 6 ft 7 in (2.00 m), 9,259 lb (4 200 kg) counterweight												
24 ft 7 in (7.5 m)										13 ft 9 in (4.19 m)	10,560 lb (4 790 kg)*	10,560 lb (4 790 kg)*
19 ft 8 in (6.0 m)			9,502 lb (4 310 kg)*	9,502 lb (4 310 kg)*						18 ft 10 in (5.75 m)	9,678 lb (4 390 kg)*	7,143 lb (3 240 kg)
14 ft 9 in (4.5 m)			10,869 lb (4 930 kg)*	10,318 lb (4 680 kg)	9,590 lb (4 350 kg)*	6,614 lb (3 000 kg)				21 ft 8 in (6.6 m)	8,818 lb (4 000 kg)	5,622 lb (2 550 kg)
9 ft 10 in (3.0 m)			13,382 lb (6 070 kg)*	9,590 lb (4 350 kg)	10,053 lb (4 560 kg)	6,349 lb (2 880 kg)				23 ft 1 in (7.03 m)	7,870 lb (3 570 kg)	4,960 lb (2 250 kg)
4 ft 11 in (1.5 m)			14,925 lb (6 770 kg)	8,973 lb (4 070 kg)	9,766 lb (4 430 kg)	6,063 lb (2 750 kg)				23 ft 4 in (7.12 m)	7,606 lb (3 450 kg)	4,762 lb (2 160 kg)
0 ft (0 m)			14,617 lb (6 630 kg)	8,686 lb (3 940 kg)	9,568 lb (4 340 kg)	5,908 lb (2 680 kg)				22 ft 6 in (6.87 m)	7,937 lb (3 600 kg)	4,938 lb (2 240 kg)
-4 ft 11 in (-1.5 m)	22,796 lb (10 340 kg)*	16,138 lb (7 320 kg)	14,617 lb (6 630 kg)	8,708 lb (3 950 kg)	9,612 lb (4 360 kg)	5,930 lb (2 690 kg)				20 ft 6 in (6.24 m)	9,127 lb (4 140 kg)	5,666 lb (2 570 kg)

REAR BLADE UP - 2-piece boom 16 ft 9 in (5.097 m), arm 6 ft 7 in (2.00 m), 9,259 lb (4 200 kg) counterweight												
24 ft 7 in (7.5 m)										13 ft 9 in (4.19 m)	10,560 lb (4 790 kg)*	10,560 lb (4 790 kg)*
19 ft 8 in (6.0 m)			9,502 lb (4 310 kg)*	9,502 lb (4 310 kg)*						18 ft 10 in (5.75 m)	9,678 lb (4 390 kg)*	6,437 lb (2 920 kg)
14 ft 9 in (4.5 m)			10,869 lb (4 930 kg)*	9,303 lb (4 220 kg)	9,590 lb (4 350 kg)*	5,952 lb (2 700 kg)				21 ft 8 in (6.6 m)	8,818 lb (4 000 kg)	5,049 lb (2 290 kg)
9 ft 10 in (3.0 m)			13,382 lb (6 070 kg)*	8,598 lb (3 900 kg)	10,053 lb (4 560 kg)	5,710 lb (2 590 kg)				23 ft 1 in (7.03 m)	7,870 lb (3 570 kg)	4,453 lb (2 020 kg)
4 ft 11 in (1.5 m)			14,925 lb (6 770 kg)	7,981 lb (3 620 kg)	9,766 lb (4 430 kg)	5,423 lb (2 460 kg)				23 ft 4 in (7.12 m)	7,606 lb (3 450 kg)	4,255 lb (1 930 kg)
0 ft (0 m)			14,617 lb (6 630 kg)	7,716 lb (3 500 kg)	9,568 lb (4 340 kg)	5,269 lb (2 390 kg)				22 ft 6 in (6.87 m)	7,937 lb (3 600 kg)	4,409 lb (2 000 kg)
-4 ft 11 in (-1.5 m)	22,796 lb (10 340 kg)*	14,110 lb (6 400 kg)	14,617 lb (6 630 kg)	7,738 lb (3 510 kg)	9,612 lb (4 360 kg)	5,291 lb (2 400 kg)				20 ft 6 in (6.24 m)	9,127 lb (4 140 kg)	5,049 lb (2 290 kg)

REAR BLADE DOWN - 2-piece boom 16 ft 9 in (5.097 m), arm 8 ft 0 in (2.45 m), 9,259 lb (4 200 kg) counterweight												
24 ft 7 in (7.5 m)			8,907 lb (4 040 kg)*	8,907 lb (4 040 kg)*						16 ft 3 in (4.95 m)	7,231 lb (3 280 kg)*	7,231 lb (3 280 kg)*
19 ft 8 in (6.0 m)			8,422 lb (3 820 kg)*	8,422 lb (3 820 kg)*	8,598 lb (3 900 kg)*	6,768 lb (3 070 kg)				20 ft 8 in (6.31 m)	6,129 lb (2 780 kg)*	6,129 lb (2 780 kg)*
14 ft 9 in (4.5 m)			9,855 lb (4 470 kg)*	9,855 lb (4 470 kg)*	8,841 lb (4 010 kg)*	6,658 lb (3 020 kg)				23 ft 4 in (7.1 m)	5,732 lb (2 600 kg)*	4,982 lb (2 260 kg)
9 ft 10 in (3.0 m)			12,412 lb (5 630 kg)*	9,722 lb (4 410 kg)	9,877 lb (4 480 kg)*	6,349 lb (2 880 kg)	5,754 lb (2 610 kg)*	4,453 lb (2 020 kg)		24 ft 7 in (7.5 m)	5,710 lb (2 590 kg)*	4,453 lb (2 020 kg)
4 ft 11 in (1.5 m)			14,925 lb (6 770 kg)*	8,995 lb (4 080 kg)	9,744 lb (4 420 kg)	6,041 lb (2 740 kg)	7,011 lb (3 180 kg)	4,365 lb (1 980 kg)		24 ft 10 in (7.58 m)	5,952 lb (2 700 kg)*	4,277 lb (1 940 kg)
0 ft (0 m)			14,550 lb (6 600 kg)	8,620 lb (3 910 kg)	9,502 lb (4 310 kg)	5,820 lb (2 640 kg)				24 ft 1 in (7.35 m)	6,570 lb (2 980 kg)*	4,431 lb (2 010 kg)
-4 ft 11 in (-1.5 m)	20,084 lb (9 110 kg)*	15,807 lb (7 170 kg)	14,462 lb (6 560 kg)	8,554 lb (3 880 kg)	9,436 lb (4 280 kg)	5,776 lb (2 620 kg)				22 ft 3 in (6.77 m)	7,782 lb (3 530 kg)*	4,960 lb (2 250 kg)
-9 ft 10 in (-3.0 m)			14,065 lb (6 380 kg)*	8,752 lb (3 970 kg)						-	-	-

REAR BLADE DOWN (WIDE AXLES) - 2-piece boom 16 ft 9 in (5.097 m), arm 8 ft 0 in (2.45 m), 9,259 lb (4 200 kg) counterweight												
24 ft 7 in (7.5 m)			8,907 lb (4 040 kg)*	8,907 lb (4 040 kg)*						16 ft 3 in (4.95 m)	7,231 lb (3 280 kg)*	7,231 lb (3 280 kg)*
19 ft 8 in (6.0 m)			8,422 lb (3 820 kg)*	8,422 lb (3 820 kg)*	8,598 lb (3 900 kg)*	7,606 lb (3 450 kg)				20 ft 8 in (6.31 m)	6,129 lb (2 780 kg)*	6,129 lb (2 780 kg)*
14 ft 9 in (4.5 m)			9,855 lb (4 470 kg)*	9,855 lb (4 470 kg)*	8,841 lb (4 010 kg)*	7,496 lb (3 400 kg)				23 ft 4 in (7.1 m)	5,732 lb (2 600 kg)*	5,644 lb (2 560 kg)
9 ft 10 in (3.0 m)			12,412 lb (5 630 kg)*	11,023 lb (5 000 kg)	9,877 lb (4 480 kg)*	6,349 lb (2 880 kg)	5,754 lb (2 610 kg)*	5,049 lb (2 290 kg)		24 ft 7 in (7.5 m)	5,710 lb (2 590 kg)*	5,049 lb (2 290 kg)
4 ft 11 in (1.5 m)			14,925 lb (6 770 kg)*	10,296 lb (4 670 kg)	9,789 lb (4 440 kg)	6,856 lb (3 110 kg)	7,033 lb (3 190 kg)	4,960 lb (2 250 kg)		24 ft 10 in (7.58 m)	5,952 lb (2 700 kg)*	4,872 lb (2 210 kg)
0 ft (0 m)			14,617 lb (6 630 kg)	9,899 lb (4 490 kg)	9,546 lb (4 330 kg)	6,636 lb (3 010 kg)				24 ft 1 in (7.35 m)	6,570 lb (2 980 kg)*	5,049 lb (2 290 kg)
-4 ft 11 in (-1.5 m)	20,084 lb (9 110 kg)*	18,563 lb (8 420 kg)	14,528 lb (6 590 kg)	9,833 lb (4 460 kg)	9,480 lb (4 300 kg)	6,592 lb (2 990 kg)				22 ft 3 in (6.77 m)	7,782 lb (3 530 kg)*	5,666 lb (2 570 kg)
-9 ft 10 in (-3.0 m)			14,065 lb (6 380 kg)*	10,031 lb (4 550 kg)						-	-	-

REAR BLADE UP - 2-piece boom 16 ft 9 in (5.097 m), arm 8 ft 0 in (2.45 m), 9,259 lb (4 200 kg) counterweight												
24 ft 7 in (7.5 m)			8,907 lb (4 040 kg)*	8,907 lb (4 040 kg)*						16 ft 3 in (4.95 m)	7,231 lb (3 280 kg)*	7,231 lb (3 280 kg)*
19 ft 8 in (6.0 m)			8,422 lb (3 820 kg)*	8,422 lb (3 820 kg)*	8,598 lb (3 900 kg)*	6,107 lb (2 770 kg)				20 ft 8 in (6.31 m)	6,129 lb (2 780 kg)*	5,534 lb (2 510 kg)
14 ft 9 in (4.5 m)			9,855 lb (4 470 kg)*	9,458 lb (4 290 kg)	8,841 lb (4 010 kg)*	6,019 lb (2 730 kg)				23 ft 4 in (7.1 m)	5,732 lb (2 600 kg)*	4,475 lb (2 030 kg)
9 ft 10 in (3.0 m)			12,412 lb (5 630 kg)*	8,708 lb (3 950 kg)	9,877 lb (4 480 kg)*	5,710 lb (2 590 kg)	5,754 lb (2 610 kg)*	3,990 lb (1 810 kg)		24 ft 7 in (7.5 m)	5,710 lb (2 590 kg)*	3,990 lb (1 810 kg)
4 ft 11 in (1.5 m)			14,925 lb (6 770 kg)*	8,025 lb (3 640 kg)	9,744 lb (4 420 kg)	5,401 lb (2 450 kg)	7,011 lb (3 180 kg)	3,880 lb (1 760 kg)		24 ft 10 in (7.58 m)	5,952 lb (2 700 kg)*	3,814 lb (1 730 kg)
0 ft (0 m)			14,550 lb (6 600 kg)	7,650 lb (3 470 kg)	9,502 lb (4 310 kg)	5,181 lb (2 350 kg)				24 ft 1 in (7.35 m)	6,570 lb (2 980 kg)*	3,946 lb (1 790 kg)
-4 ft 11 in (-1.5 m)	20,084 lb (9 110 kg)*	13,801 lb (6 260 kg)	14,462 lb (6 560 kg)	7,562 lb (3 430 kg)	9,436 lb (4 280 kg)	5,137 lb (2 330 kg)				22 ft 3 in (6.77 m)	7,782 lb (3 530 kg)*	4,431 lb (2 010 kg)
-9 ft 10 in (-3.0 m)			14,065 lb (6 380 kg)*	7,760 lb (3 520 kg)						-	-	-

NOTE: *The above loads (kg) are compliant to the ISO standards and refer to the excavator equipped without bucket. The indicated loads are no more than 87% of hydraulic system lift capacity or 75% of static tipping load. Values marked with an asterisk (*) are limited by the hydraulic lifting capacity.

LIFTING CAPACITIES - 2-PIECE BOOM

Load/Lift Point Height	LOAD RADIUS								MAXIMUM REACH			
	4 ft 11 in (1.5 m)		9 ft 10 in (3.0 m)		14 ft 9 in (4.5 m)		19 ft 8 in (6.0 m)		REACH	CAPACITY		
	END	SIDE	END	SIDE	END	SIDE	END	SIDE	@	END	SIDE	
REAR BLADE UP (WIDE AXLES) - 2-piece boom 16 ft 9 in (5.097 m), arm 8 ft 0 in (2.45 m), 9,259 lb (4 200 kg) counterweight												
24 ft 7 in (7.5 m)			8,907 lb (4 040 kg)*	8,907 lb (4 040 kg)*						16 ft 3 in (4.95 m)	7,231 lb (3 280 kg)*	7,231 lb (3 280 kg)*
19 ft 8 in (6.0 m)			8,422 lb (3 820 kg)*	8,422 lb (3 820 kg)*	8,598 lb (3 900 kg)*	6,746 lb (3 060 kg)				20 ft 8 in (6.31 m)	6,129 lb (2 780 kg)*	6,129 lb (2 780 kg)*
14 ft 9 in (4.5 m)			9,855 lb (4 470 kg)*	9,855 lb (4 470 kg)*	8,841 lb (4 010 kg)*	6,636 lb (3 010 kg)				23 ft 4 in (7.1 m)	5,732 lb (2 600 kg)*	4,960 lb (2 250 kg)
9 ft 10 in (3.0 m)			12,412 lb (5 630 kg)*	9,678 lb (4 390 kg)	9,877 lb (4 480 kg)*	6,349 lb (2 880 kg)	5,754 lb (2 610 kg)*	4,453 lb (2 020 kg)		24 ft 7 in (7.5 m)	5,710 lb (2 590 kg)*	4,453 lb (2 020 kg)
4 ft 11 in (1.5 m)			14,925 lb (6 770 kg)*	8,973 lb (4 070 kg)	9,789 lb (4 440 kg)	6,019 lb (2 730 kg)	7,033 lb (3 190 kg)	4,343 lb (1 970 kg)		24 ft 10 in (7.58 m)	5,952 lb (2 700 kg)*	4,277 lb (1 940 kg)
0 ft (0 m)			14,617 lb (6 630 kg)	8,598 lb (3 900 kg)	9,546 lb (4 330 kg)	5,798 lb (2 630 kg)				24 ft 1 in (7.35 m)	6,570 lb (2 980 kg)*	4,409 lb (2 000 kg)
-4 ft 11 in (-1.5 m)	20,084 lb (9 110 kg)*	15,741 lb (7 140 kg)	14,528 lb (6 590 kg)	8,532 lb (3 870 kg)	9,480 lb (4 300 kg)	5,754 lb (2 610 kg)				22 ft 3 in (6.77 m)	7,782 lb (3 530 kg)*	4,960 lb (2 250 kg)
-9 ft 10 in (-3.0 m)			14,065 lb (6 380 kg)*	8,730 lb (3 960 kg)						-	-	-

FRONT BLADE & REAR STABILIZERS DOWN - 2-piece boom 16 ft 9 in (5.097 m), arm 8 ft 0 in (2.45 m), 9,259 lb (4 200 kg) counterweight												
24 ft 7 in (7.5 m)			8,907 lb (4 040 kg)*	8,907 lb (4 040 kg)*						16 ft 3 in (4.95 m)	7,231 lb (3 280 kg)*	7,231 lb (3 280 kg)*
19 ft 8 in (6.0 m)			8,422 lb (3 820 kg)*	8,422 lb (3 820 kg)*	8,598 lb (3 900 kg)*	8,598 lb (3 900 kg)*				20 ft 8 in (6.31 m)	6,129 lb (2 780 kg)*	6,129 lb (2 780 kg)*
14 ft 9 in (4.5 m)			9,855 lb (4 470 kg)*	9,855 lb (4 470 kg)*	8,841 lb (4 010 kg)*	8,841 lb (4 010 kg)*				23 ft 4 in (7.1 m)	5,732 lb (2 600 kg)*	5,732 lb (2 600 kg)*
9 ft 10 in (3.0 m)			12,412 lb (5 630 kg)*	12,412 lb (5 630 kg)*	9,877 lb (4 480 kg)*	9,877 lb (4 480 kg)*	5,754 lb (2 610 kg)*	5,754 lb (2 610 kg)*		24 ft 7 in (7.5 m)	5,710 lb (2 590 kg)*	5,710 lb (2 590 kg)*
4 ft 11 in (1.5 m)			14,925 lb (6 770 kg)*	14,925 lb (6 770 kg)*	11,067 lb (5 020 kg)*	10,450 lb (4 740 kg)	7,738 lb (3 510 kg)*	7,540 lb (3 420 kg)		24 ft 10 in (7.58 m)	5,952 lb (2 700 kg)*	5,952 lb (2 700 kg)*
0 ft (0 m)			16,270 lb (7 380 kg)*	15,675 lb (7 110 kg)	11,839 lb (5 370 kg)*	10,207 lb (4 630 kg)				24 ft 1 in (7.35 m)	6,570 lb (2 980 kg)*	6,570 lb (2 980 kg)*
-4 ft 11 in (-1.5 m)	20,084 lb (9 110 kg)*	20,084 lb (9 110 kg)*	16,116 lb (7 310 kg)*	15,587 lb (7 070 kg)	11,684 lb (5 300 kg)*	10,163 lb (4 610 kg)				22 ft 3 in (6.77 m)	7,782 lb (3 530 kg)*	7,782 lb (3 530 kg)*
-9 ft 10 in (-3.0 m)			14,065 lb (6 380 kg)*	14,065 lb (6 380 kg)*						-	-	-

FRONT BLADE & REAR STABILIZERS UP - 2-piece boom 16 ft 9 in (5.097 m), arm 8 ft 0 in (2.45 m), 9,259 lb (4 200 kg) counterweight												
24 ft 7 in (7.5 m)			8,907 lb (4 040 kg)*	8,907 lb (4 040 kg)*						16 ft 3 in (4.95 m)	7,231 lb (3 280 kg)*	7,231 lb (3 280 kg)*
19 ft 8 in (6.0 m)			8,422 lb (3 820 kg)*	8,422 lb (3 820 kg)*	8,598 lb (3 900 kg)*	7,716 lb (3 500 kg)				20 ft 8 in (6.31 m)	6,129 lb (2 780 kg)*	6,129 lb (2 780 kg)*
14 ft 9 in (4.5 m)			9,855 lb (4 470 kg)*	9,855 lb (4 470 kg)*	8,841 lb (4 010 kg)*	7,606 lb (3 450 kg)				23 ft 4 in (7.1 m)	5,732 lb (2 600 kg)*	5,732 lb (2 600 kg)
9 ft 10 in (3.0 m)			12,412 lb (5 630 kg)*	11,155 lb (5 060 kg)	9,877 lb (4 480 kg)*	7,297 lb (3 310 kg)	5,754 lb (2 610 kg)*	5,159 lb (2 340 kg)		24 ft 7 in (7.5 m)	5,710 lb (2 590 kg)*	5,159 lb (2 340 kg)
4 ft 11 in (1.5 m)			14,925 lb (6 770 kg)*	10,428 lb (4 730 kg)	9,855 lb (4 470 kg)	6,989 lb (3 170 kg)	7,099 lb (3 220 kg)	5,049 lb (2 290 kg)		24 ft 10 in (7.58 m)	5,952 lb (2 700 kg)*	4,982 lb (2 260 kg)
0 ft (0 m)			14,705 lb (6 670 kg)	10,031 lb (4 550 kg)	9,612 lb (4 360 kg)	6,768 lb (3 070 kg)				24 ft 1 in (7.35 m)	6,570 lb (2 980 kg)*	5,137 lb (2 330 kg)
-4 ft 11 in (-1.5 m)	20,084 lb (9 110 kg)*	18,607 lb (8 440 kg)	14,639 lb (6 640 kg)	9,965 lb (4 520 kg)	9,568 lb (4 340 kg)	6,702 lb (3 040 kg)				22 ft 3 in (6.77 m)	7,782 lb (3 530 kg)*	5,776 lb (2 620 kg)
-9 ft 10 in (-3.0 m)			14,065 lb (6 380 kg)*	10,163 lb (4 610 kg)						-	-	-

REAR BLADE DOWN - 2-piece boom 16 ft 9 in (5.097 m), arm 8 ft 6 in (2.60 m), 9,259 lb (4 200 kg) counterweight												
24 ft 7 in (7.5 m)			8,400 lb (3 810 kg)*	8,400 lb (3 810 kg)*						16 ft 11 in (5.15 m)	7,672 lb (3 480 kg)*	7,672 lb (3 480 kg)*
19 ft 8 in (6.0 m)			8,069 lb (3 660 kg)*	8,069 lb (3 660 kg)*	8,245 lb (3 740 kg)*	6,812 lb (3 090 kg)				21 ft 3 in (6.47 m)	6,592 lb (2 990 kg)*	5,908 lb (2 680 kg)
14 ft 9 in (4.5 m)			9,502 lb (4 310 kg)*	9,502 lb (4 310 kg)*	8,598 lb (3 900 kg)*	6,680 lb (3 030 kg)				23 ft 9 in (7.24 m)	6,239 lb (2 830 kg)*	4,828 lb (2 190 kg)
9 ft 10 in (3.0 m)			12,081 lb (5 480 kg)*	9,766 lb (4 430 kg)	9,678 lb (4 390 kg)*	6,371 lb (2 890 kg)	7,121 lb (3 230 kg)	4,453 lb (2 020 kg)		25 ft 0 in (7.63 m)	6,217 lb (2 820 kg)*	4,321 lb (1 960 kg)
4 ft 11 in (1.5 m)			14,683 lb (6 660 kg)*	9,017 lb (4 090 kg)	9,744 lb (4 420 kg)	6,041 lb (2 740 kg)	6,989 lb (3 170 kg)	4,343 lb (1 970 kg)		25 ft 4 in (7.71 m)	6,504 lb (2 950 kg)*	4,167 lb (1 890 kg)
0 ft (0 m)			14,528 lb (6 590 kg)	8,598 lb (3 900 kg)	9,480 lb (4 300 kg)	5,798 lb (2 630 kg)				24 ft 6 in (7.48 m)	6,945 lb (3 150 kg)	4,277 lb (1 940 kg)
-4 ft 11 in (-1.5 m)	19,577 lb (8 880 kg)*	15,719 lb (7 130 kg)	14,418 lb (6 540 kg)	8,488 lb (3 850 kg)	9,414 lb (4 270 kg)	5,732 lb (2 600 kg)				22 ft 8 in (6.91 m)	7,760 lb (3 520 kg)	4,784 lb (2 170 kg)
-9 ft 10 in (-3.0 m)			14,352 lb (6 510 kg)*	8,664 lb (3 930 kg)						-	-	-

REAR BLADE UP - 2-piece boom 16 ft 9 in (5.097 m), arm 8 ft 6 in (2.60 m), 9,259 lb (4 200 kg) counterweight												
24 ft 7 in (7.5 m)			8,400 lb (3 810 kg)*	8,400 lb (3 810 kg)*						16 ft 11 in (5.15 m)	7,672 lb (3 480 kg)*	7,672 lb (3 480 kg)*
19 ft 8 in (6.0 m)			8,069 lb (3 660 kg)*	8,069 lb (3 660 kg)*	8,245 lb (3 740 kg)*	6,151 lb (2 790 kg)				21 ft 3 in (6.47 m)	6,592 lb (2 990 kg)*	5,335 lb (2 420 kg)
14 ft 9 in (4.5 m)			9,502 lb (4 310 kg)*	9,502 lb (4 310 kg)*	8,598 lb (3 900 kg)*	6,041 lb (2 740 kg)				23 ft 9 in (7.24 m)	6,239 lb (2 830 kg)*	4,343 lb (1 970 kg)
9 ft 10 in (3.0 m)			12,081 lb (5 480 kg)*	8,752 lb (3 970 kg)	9,678 lb (4 390 kg)*	5,732 lb (2 600 kg)	7,121 lb (3 230 kg)	3,990 lb (1 810 kg)		25 ft 0 in (7.63 m)	6,217 lb (2 820 kg)*	3,858 lb (1 750 kg)
4 ft 11 in (1.5 m)			14,683 lb (6 660 kg)*	8,025 lb (3 640 kg)	9,744 lb (4 420 kg)	5,401 lb (2 450 kg)	6,989 lb (3 170 kg)	3,880 lb (1 760 kg)		25 ft 4 in (7.71 m)	6,504 lb (2 950 kg)*	3,704 lb (1 680 kg)
0 ft (0 m)			14,528 lb (6 590 kg)	7,628 lb (3 460 kg)	9,480 lb (4 300 kg)	5,159 lb (2 340 kg)				24 ft 6 in (7.48 m)	6,945 lb (3 150 kg)	3,814 lb (1 730 kg)
-4 ft 11 in (-1.5 m)	19,577 lb (8 880 kg)*	13,691 lb (6 210 kg)	14,418 lb (6 540 kg)	7,518 lb (3 410 kg)	9,414 lb (4 270 kg)	5,093 lb (2 310 kg)				22 ft 8 in (6.91 m)	7,760 lb (3 520 kg)	4,255 lb (1 930 kg)
-9 ft 10 in (-3.0 m)			14,352 lb (6 510 kg)*	7,694 lb (3 490 kg)						-	-	-

NOTE: *The above loads (kg) are compliant to the ISO standards and refer to the excavator equipped without bucket. The indicated loads are no more than 87% of hydraulic system lift capacity or 75% of static tipping load. Values marked with an asterisk (*) are limited by the hydraulic lifting capacity.

STANDARD EQUIPMENT

ENGINE

Cummins B4.5, water-cooled, 4-cylinder in line, 4.5-liter, high pressure common rail system (electronic control), waste gate turbocharger with air cooled intercooler, DOC+DPF+SCR aftertreatment, EGR free engine

Rated flywheel horsepower:

ISO 9249	170 hp (127 kW) @ 2200 RPM
ISO 14396	173 hp (129 kW) @ 2200 RPM

Maximum torque:

ISO 14396	575 ft-lb (780 Nm) @ 1500 RPM
-----------	-------------------------------

Tier 4 Final / Stage V certified

Ultra-low sulfur diesel and B7 biodiesel fuel certified

ECO gauge fuel efficiency indicator

Detailed historical fuel, work modes and throttle position utilization report

Variable power control on jog dial

Automatic, postponable after-treatment filter cleaning

Programmable electronically-controlled reversible fan

Programmable engine Auto Idle and Auto Shutdown functions

Automatic or manually controlled 9.2 gpm (35 L/min) electric refuel pump

DEF tank overload warning

Air intake cup-type pre-cleaner

Dual dry-type element air filter with warning restriction indicator

Air grid heater starting aid

Replaceable, full flow spin-on fuel and engine oil cartridges

Fuel pre-filter with water drain

Stacked cooling pack configuration

Protective screen for radiators

HYDRAULIC SYSTEM

Load sensing hydraulic system (LUDV) with advanced flow sharing hydraulics

3 - selectable work modes: Heavy Duty, Standard and Economy

1 - selectable user customized work mode - engine speed, idle speed, machine speed and pump flow

High flow multi-function with pressure setting circuit for one-way and two-way flow attachments

In monitor hydraulic settings storage and management for 10 one-way and 10 two-way attachments

3 - attachment work modes - push/detent/proportional

Quick coupler hydraulic circuit

Safety valves on boom with overload warning

Safety valves on arm, dozer blade, front axle oscillation cylinders

Power boost mode activated on joystick

Accumulator on boom cylinders for cushioning ride control system

Boom float control

High pressure hoses

Main pump Variable displacement piston pump

Max. oil flow	68.9 gpm (261 l/min) @ 1800 RPM
---------------	---------------------------------

Working circuit pressures

Boom/Arm/Bucket	4,975 psi (34.3 MPa) / 5,410 psi (37.3 MPa) with auto power boost
Swing circuit	3,844 psi (26.5 MPa)
Travel circuit	5,410 psi (37.3 MPa)
Pilot circuit	493 psi (3.4 MPa)

SWING

Fixed displacement radial piston swing motor

Automatic, spring applied hydraulic release (SAHR) swing brake system

Fine swing for precise and smooth upper carriage rotation

Swing lock to prevent undesirable upper carriage rotation

Maximum swing speed	9.5 RPM
Swing torque	28,839 ft-lb (39 100 Nm)

ELECTRICAL SYSTEM

Battery disconnect switch

Emergency engine stop switch

Voltage	24 V
Alternator	95 amp
Starter	24 V - 4.8 kW
Batteries	2 X 12 V - 100 Ah

UNDERCARRIAGE

Removable parallel mounting bolt-on designed rear blade and front stabilizers

Trailer hitch mount/provision with electrical connector for lights and hydraulic trailer dump single auxiliary hydraulic line (return by gravity)

Cab access steps

Toolbox with upper carriage access steps

Lashing points (tie downs)

UPPER CARRIAGE

Standard counterweight

Front and right-hand side handrails

Lockable cab door, fuel and DEF tanks, service doors and tool box

Rear work lamp

Head lights and indicator lights

LED working lights package

ATTACHMENTS

2-piece boom

Digging arm	8 ft 6 in (2.6 m)
-------------	-------------------

Digging arm reinforcements

Reinforced pins, bushings and polymer shims

DRIVELINE

2-speed hydrostatic powershift transmission

Permanent 4-wheel drive and front axle steering

Variable displacement bent-axis axial piston travel motor

Orbitrol steering system

Emergency steering system

Minimum turning radius	20 ft 8 in (6.3 m)
------------------------	--------------------

Automatic or manually controlled front axle oscillation lock

Fixed rear axle

4-sets of twin pneumatic tires

Wet multi-disc work/travel brakes

Wet multi-disc integrated in transmission park brake

Travel alarm

All around composite fenders - steerable on the front axle

High travel speed (Automatic travel speed shifting)

	22 mph (35 km/h)
Low travel speed	6.2 mph (10 km/h)
Creep speed	1.9 mph (3 km/h)

Drawbar pull

	20,458 lbf (91 kN)
--	--------------------

Gradeability

	70% (35°)
--	-----------

OPERATOR'S STATION

Enclosed pressurized cab with air conditioning, heat and defrost with full climate control and lockable door

ROPS/FOPS certified

Standard same ignition key and all-around anti-vandalism key

One piece sliding fold-in front window and sliding left-hand side window

Safety glass for all windows, including laminated glass for front window for added protection

Sliding side window (left-hand)

High-back premium heated air-suspension and tilting seat

Sliding fore/after, weight, height, pan angle, depth, lumbar and backrest seat adjustments

Seatbelt and seatbelt warning system

Adjustable armrests and headrest

Gate lock hydraulic activation

Low-effort joystick controls

Joystick equipped proportional control, FNR transmission switch, detent activation and front axle oscillation lock

Selectable steering wheel or right-hand joystick steering

Slim 3-way adjustable steering column design

8 in touchscreen monitor with instruments cluster

Instrument cluster navigation, air conditioning control and engine throttle powered by right-hand console jog dial module

Instrument cluster gauges: engine RPM, engine coolant temperature, hydraulic oil temperature, fuel level, DEF level, ECO, accelerometer dial, hourmeter

CASE MaxView 360-degree 4-camera with intelligent moving object detection technology and warning system for up to 16 ft 4 in (5 m) around the machine

Radar object detection and warning system for up to 32 ft 9 in (10 m) on the rear of the machine

Audio system including radio player, USB MP3 player, aux-in port for personal electronics and Bluetooth capability for hands-free calling

12-volt electric outlet

Adjustable speed cruise control mode

Emergency FNR switch

4-wheel auto-brake mode for attachment operation

Ride control system for smooth traveling and reduced attachment spillage

Clear roof view with sunshade

Rain deflector

Interior dome light

Emergency exit and hammer

2-piece rubber floor mat

Exterior mirrors

Cup holder

Storage compartments

Warm/cool storage compartment

Electric horn

Parallel windshield wiper and windshield washer

Cab filters (internal and external)

Cab suspension mounts to minimize noise and vibration

Operator's manual

NOISE

External sound level	LwA 100 dB(A)
Operator cab sound pressure level	LpA 71 dB(A)

CIRCUIT AND COMPONENT CAPACITIES

Fuel tank	53 gal (200 L)
Hydraulic system	49.4 gal (187 L)
Hydraulic tank	27.2 gal (103 L)
DEF tank	12.7 gal (48 L)

MAINTENANCE

Full Machine Protection Factory Warranty (3-yr/3000-hr), Planned Maintenance (3-yr/2000-hr)

Single-point engine daily checks under engine hood

Self-diagnostics system

Service interval:

- 250-hr greasing on boom and arm pins and bushings
- 800-hr engine oil and filter
- 1,000-hr fuel filter and pre-filter
- 2,000-hr air filters
- 5,000-hr hydraulic oil

OPTIONAL EQUIPMENT

HYDRAULICS

Secondary low 2-way flow electronic proportional controlled auxiliary hydraulics
Fine Swing control
Cold climate hydraulic oil

OPERATOR ENVIRONMENT

Rear view camera only
Rear and right-side cameras
Smart key with push to start button

FRONT END EQUIPMENT

Digging arm	8 ft 0 in (2.45 m)
Digging arm	8 ft 6 in (2.6 m)

UPPER STRUCTURE

FOPS top cab guard
Wire mesh screen front guard
OPG Level 2 front guard

UNDERCARRIAGE

Rear blade
2F/2R stabilizers
F/R blade
Solid tires

CaseCE.com

©2023 CNH Industrial America LLC. All rights reserved. CASE is a trademark registered in the United States and many other countries, owned by or licensed to CNH Industrial N.V., its subsidiaries or affiliates. CNH Industrial Capital is a trademark in the United States and many other countries, owned by or licensed to CNH Industrial N.V., its subsidiaries or affiliates. Printed in U.S.A. Contains 10% post-consumer fiber.

IMPORTANT: CASE Construction Equipment Inc. reserves the right to change these specifications without notice and without incurring any obligation relating to such change. Availability of some models and equipment builds vary according to the country in which the equipment is used. The illustrations and text may include optional equipment and accessories and may not include all standard equipment. Your CASE dealer/distributor will be able to give you details of the products and their specifications available in your area.



CASE Construction Equipment is biodiesel-friendly. NOTE: All engines meet current EPA emissions regulations. All specifications are stated in accordance with SAE Standards or Recommended Practices, where applicable.



Always read the Operator's Manual before operating any equipment. Inspect equipment before using it, and be sure it is operating properly. Follow the product safety signs and use any safety features provided.

Form No. CCE202306WX175ESR

WX175E SR

6 of 6